

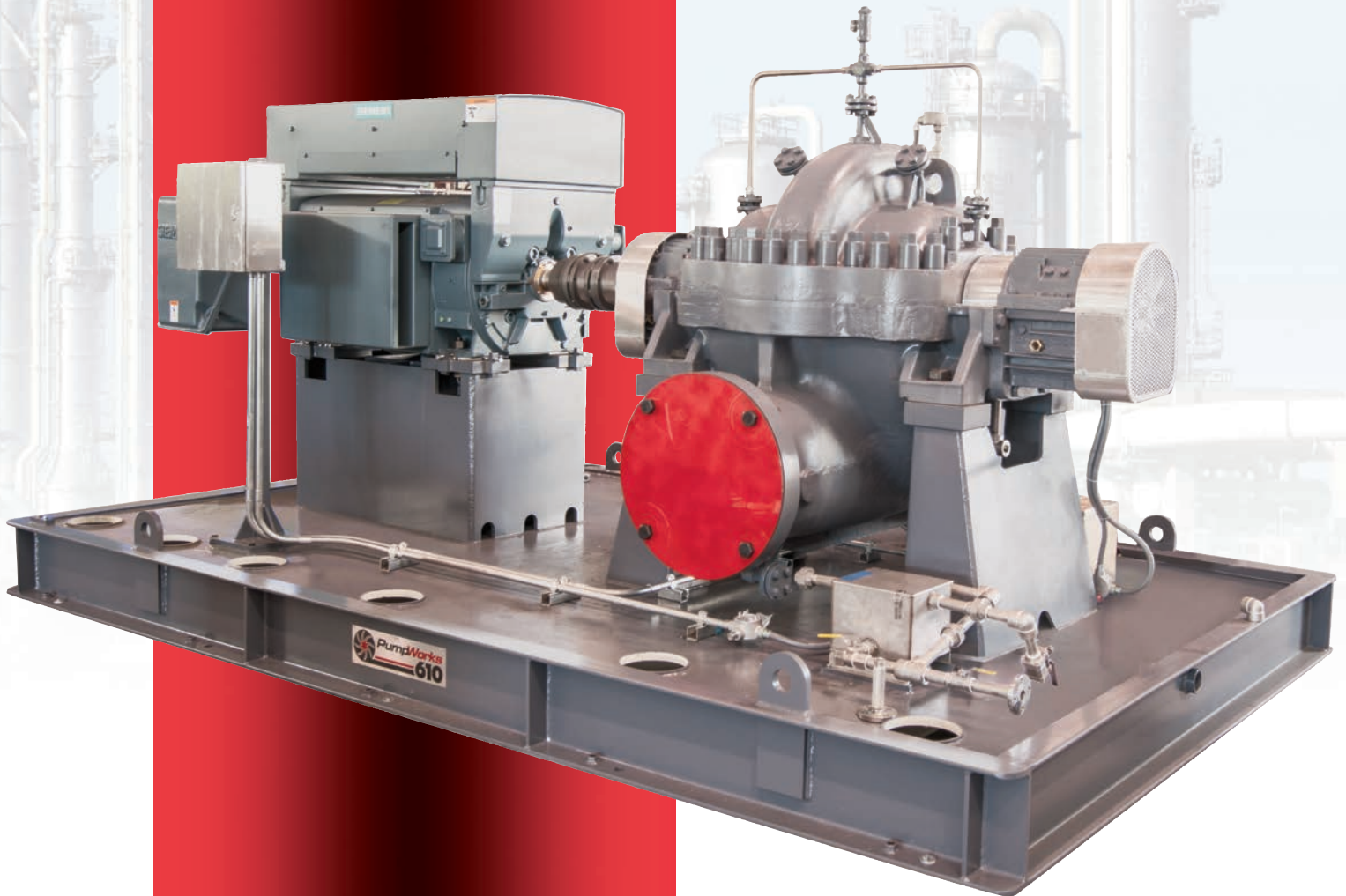

PWD

**PWD API 610 BB1
Single Stage Pump**



PWD API 610 BB1 SINGLE STAGE PUMP

HYDRAULIC PERFORMANCE COVERAGE

50 Hz Performance Coverage

Visit our web site at www.pumpworks610.com and specify flow and performance needs and obtain pump selection, performance curve, drawing, and data sheet.

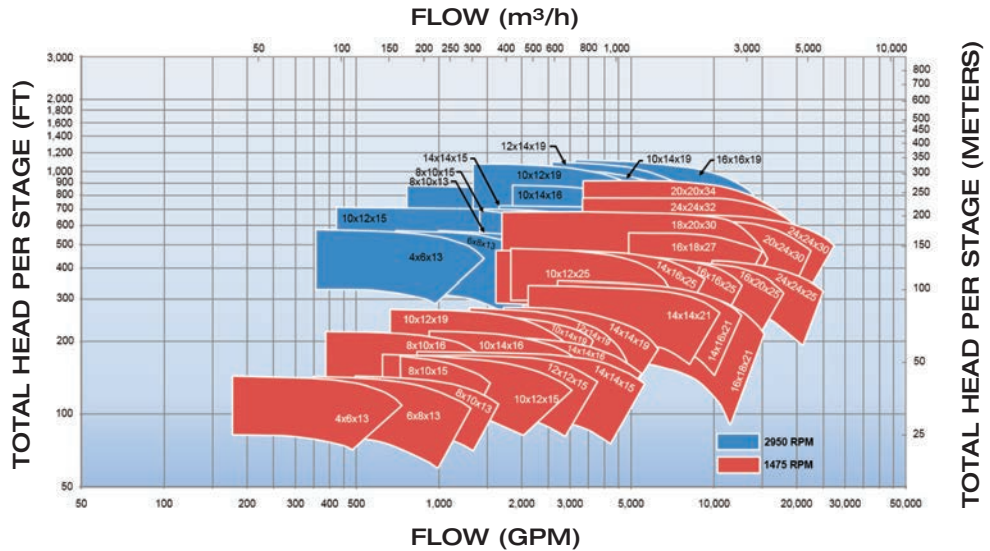

60 Hz Performance Coverage

Visit our web site at www.pumpworks610.com and specify flow and performance needs and obtain pump selection, performance curve, drawing, and data sheet.

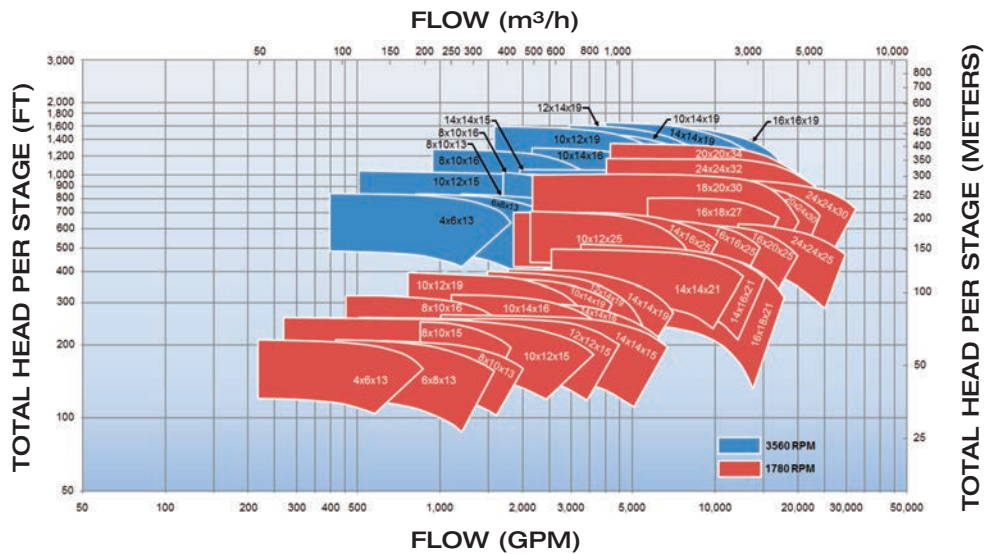

Performances shown are normal and are to be used for preliminary selection only.

STANDARD MATERIALS OF CONSTRUCTION

API MATERIAL CLASS	S-4	S-6	S-8	C-6	A-8
CASING	A-216 GRADE WCB	A216 GRADE WCB	A216 GRADE WCB	A487 GRADE CA6NM	A351 GRADE CF3M
IMPELLER	A-216 GRADE WCB	A487 GRADE CA6NM	A743 GRADE CF3M	A743 GRADE CA6NM	A743 GRADE CF3M
SHAFT	ASTM A276 TYPE 410 SS	ASTM A276 TYPE 410 SS	A479 TYPE XM-19	A276 TYPE 410 SS	A479 TYPE XM-19
BEARING HOUSING	GRADE WCB	A216 GRADE WCB CARBON STEEL	A216 GRADE WCB	A216 GRADE WCB	A216 GRADE WCB
IMPELLER WEAR RINGS	CAST IRON	262-302 BHN: 410 SS HT	316 SS HARD FACED	410 SS HT; 255-302 BHN	316 SS HARD FACED
CASING WEAR RINGS	CAST IRON	400-450 BHN: 420 SS HT	316 SS HARD FACED	420 SS: 400-450 BHN	316 SS HARD FACED
THROAT BUSHING	CAST IRON	410 SS HT: 262-302 BHN	316 SS HARD FACED	410 SS HT; 255-302 BHN	316 SS HARD FACED
CASING STUDS	A-193 GRADE B-7	A193 GRADE B-7	A193 GRADE B-7	A193 GRADE B-7	A193 GRADE B-7
CASING NUTS	A-194 GRADE 2H	A194 GRADE 2H	A194 GRADE 2H	A194 GRADE 2H	A194 GRADE 2H

*Other API 610 Material Classes and Combinations are available including D-1 and D-2.

PWD API 610 BB1 SINGLE STAGE PUMP

DESIGN FEATURES AND BENEFITS

Quality

- Manufactured and tested in the USA

Bearing Housing

- Finned design with fan cooling improves heat dissipation for lower bearing temperatures
- Large bearing housing easily accommodates vibration switches, transmitters and proximity probes
- Optional sleeve/KTB (pivot shoe) bearing designed to handle variety of RTDs

Impeller

- Precision cast for maximum efficiency
- Dynamically balanced for smooth operation to 4W/N before mounting
- Keyed to the shaft
- Double suction large eye impeller for lower NPSH performance

Delivery

- 28 weeks for API 610 material class S-4, S-6, S-8, C-6 and A-8
- Refer to the factory on deliveries for other API material classes and customer specific material combinations

Flanges

- ANSI B16.5 Class 600# RF suction & discharge flanges
- Optional 300#/900#

Nozzles

- Cast integrally in the lower half casing, permitting disassembly without disturbing piping connections

Bearing Design

- Ball / Ball
- Standard Sleeve / Ball
- Optional Sleeve / Kingsbury

Double Volute

- Precision cast hydraulic passageways minimize radial thrust for less shaft deflection and bearing loading

Labyrinth Oil Seal

- INPRO™ bearing isolators to provide op

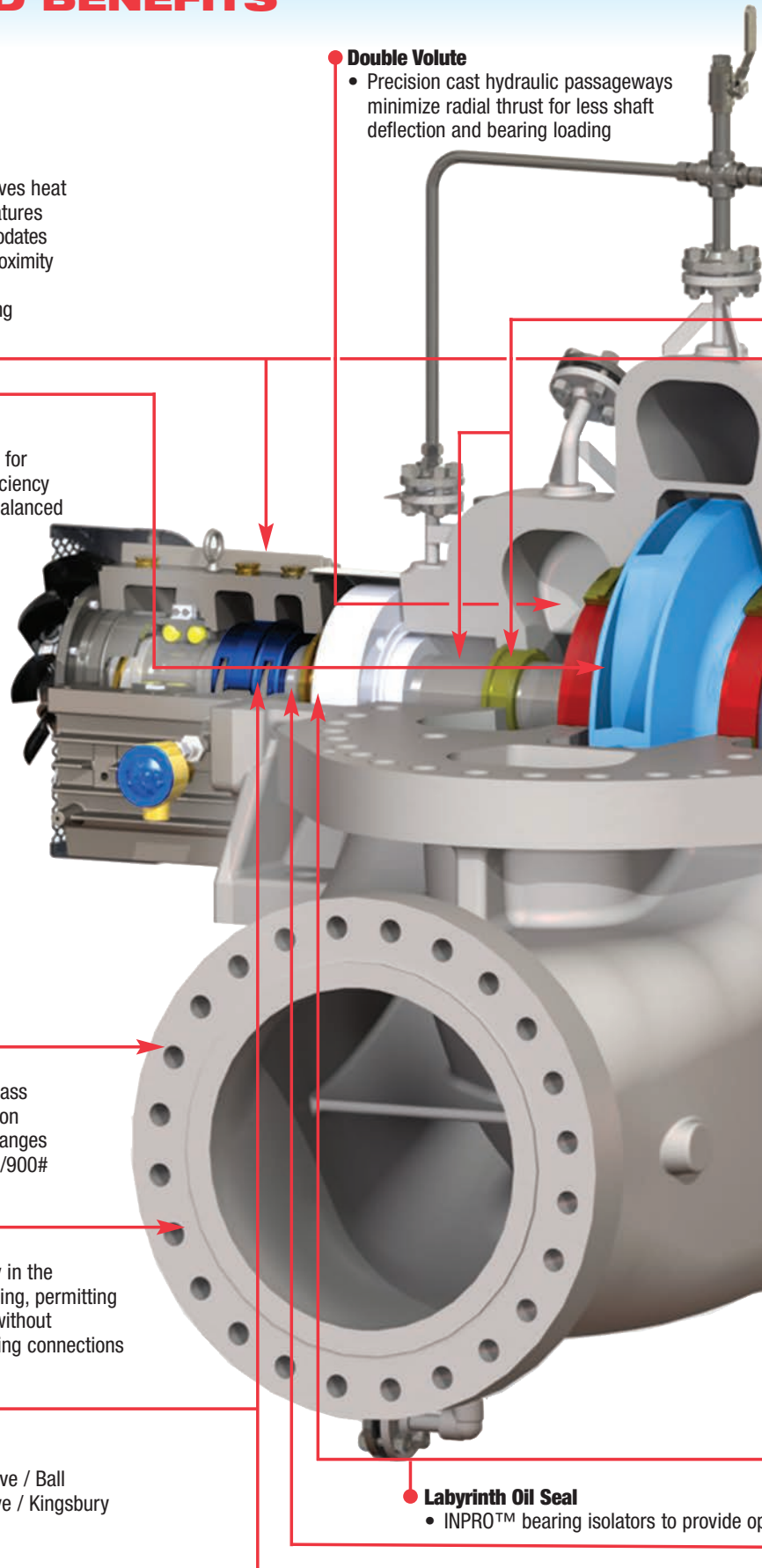

PWD API 610 CONSTRUCTION BB1 SINGLE STAGE PUMP

Renewable Wear Rings

- All wear rings are replaceable permitting re-establishing initial running clearances and efficiency
- Positively locked

Seal Chamber

- API 610 seal chamber allows user to install any API 682 cartridge seal to meet process requirements
- Renewable throat bushing for controlled seal chamber environment

Case Studs & Bolts

- Torque to 42,000 psi stress for maximum clamping force on the split line
- Case nuts are high strength Turbine type cap nuts
- Cap nuts located on top half casing parting flange allowing easy case removal for rotor inspection and maintenance

ePod Pump Selector

- Access for end users and specifiers to select and configure your pump application on line at www.pumpworks610.com

Casing

- Mounting feet cast integral into the bottom half providing near centerline mounting to minimize thermal growth in hot service
- Wide foot design to minimize affects of forces and moments imposed by the system piping
- Meets API-610 2x nozzle loads
- Hydrostatic test of pressure containing parts to 1.5 MAWP
- Socket welded and flange case vents and drains

Bearing Lubrication

- Ring oil lubrication to ensure effective lubrication
- Optional pure or purge mist lubrication
- Optional force feed pressure lubrication

Optimum bearing housing environment

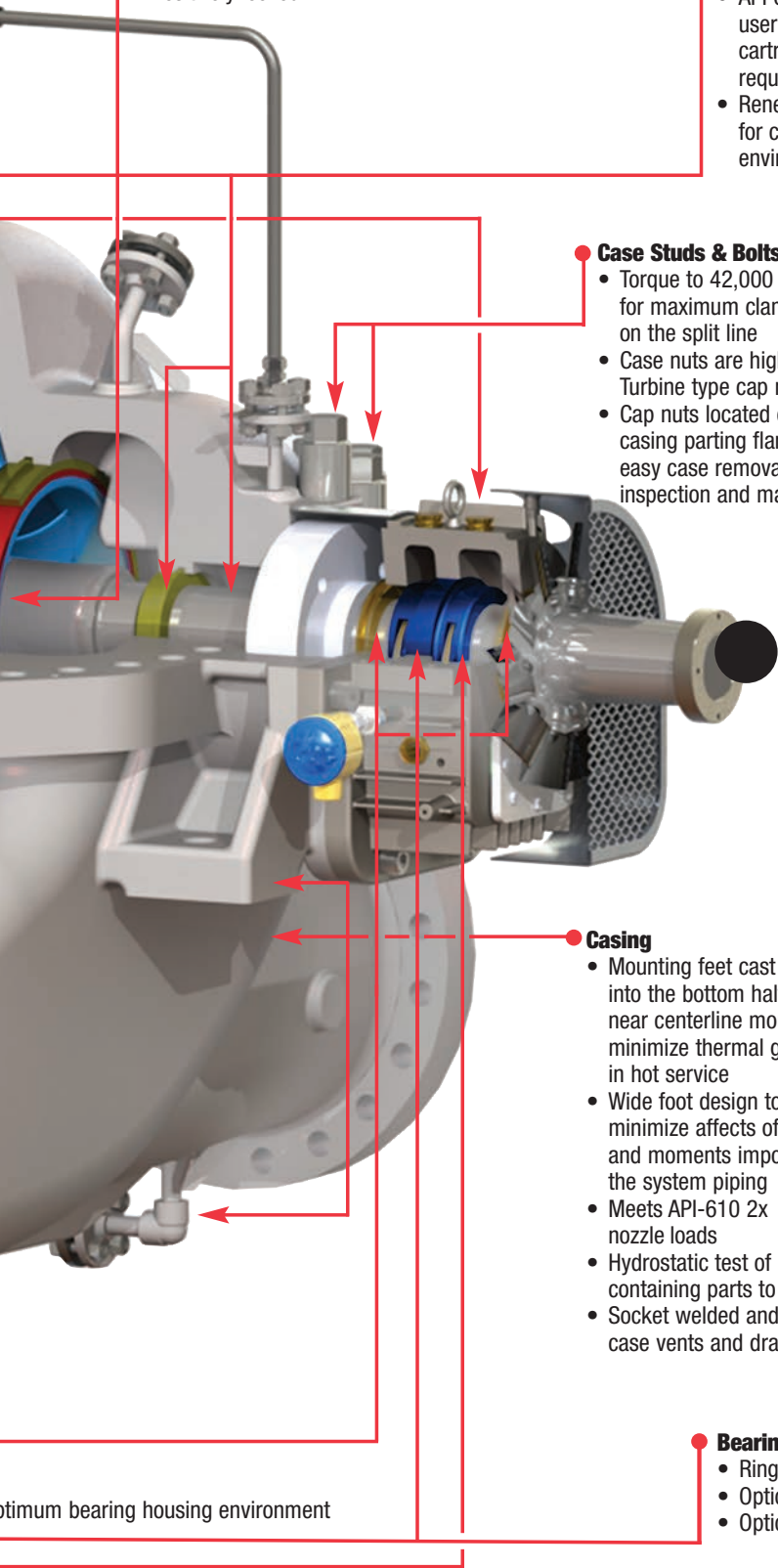

PWD API 610 BB1 SINGLE STAGE PUMP

OUTLINE DIMENSIONS

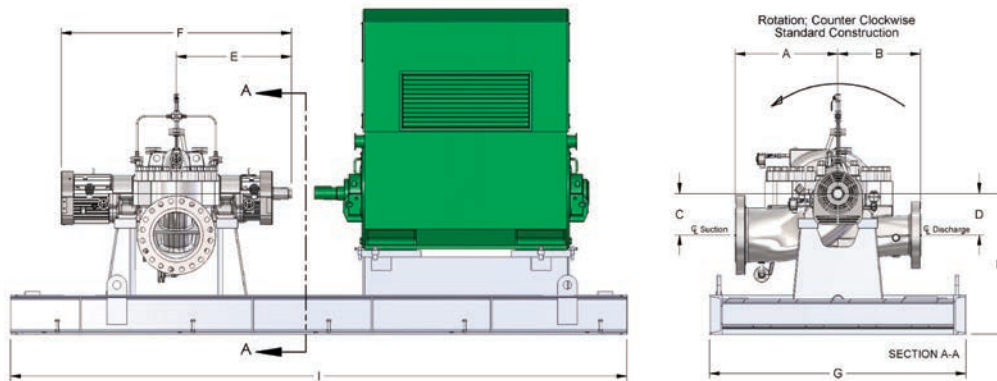

NOTES:

1. All dimensions are in inches. Dimensions are not certified for construction.
2. Standard construction flange rating 600# RF
3. All dimensions based on sleeve bearing / ball thrust housings with fan cooling.
- *4. For clockwise rotation - suction and discharge are on opposite sides in End View
5. Dimensions "I", & "G" may vary with driver selection.
- **6. Add 6" to "H", and add 54" to "I" for auxiliary lube system.
- ***7. Estimated skid weight is based on minimum length and width, and is not applicable for systems with an auxiliary lube system.

Size	*Independent of Rotation				CW & CCW Rotations		Baseplate			Weights (lbs.)	
	A	B	C	D	E	F	G	**H	**I	Pump	***Skid
4x6x13	17.00	17.00	8.00	8.00	24.50	50.25	44	32	144	850	3550
6x8x13	23.00	20.00	11.00	9.00	25.75	51.75	56	37	144	1,200	4000
8x10x13	25.00			11.00	32.50	64.50	60	39	156	2,200	4300
8x10x15	26.00	22.00	12.00	12.00	32.00	64.00	62	40	156	2,600	4400
8x10x16					33.50	66.50	62	40	156	2,600	4400
10x12x15	28.00	25.00	13.00	13.00	33.25	66.25	66	43	156	3,000	4600
10x12x19			14.00	14.00	33.00	65.00	66	44	156	3,500	4600
10x12x25	30.00	27.00	17.00	17.00	33.50	66.00	70	47	156	4,200	4800
10x14x16	28.00	25.00	13.00	13.00	34.81	69.56	66	45	156	4,000	4600
10x14x19	30.00	26.00	15.00		33.50	66.00	70	47	156	4,600	4800
12x12x15			14.00	14.00			70	44	162	4,400	4900
12x14x16	32.00	30.00	15.00	15.00	39.00	79.50	70	46	174	6,700	5050
12x14x19							74	47	162	6,800	5100
14x14x15	34.00	30.00	16.00	16.00	35.50	70.00	78	47	162	6,600	5350
14x14x16							78	47	162	6,600	5350
14x14x19	38.00	32.00	17.00	17.00	38.00	80.00	78	48	168	7,000	5450
14x14x21							86	49	174	7,200	5900
14x16x21	38.00	32.00	17.00	17.00	42.00	83.00	86	51	174	8,300	5900
14x16x25							86	51	174	8,800	5900
16x16x19	42.00	34.00	16.00	16.00	43.50	86.00	86	50	174	8,200	5900
16x16x25							86	52	174	9,000	5900
16x18x21	42.00	34.00	21.00	21.00	43.50	85.00	94	57	174	8,700	6400
16x18x27							94	57	174	9,300	6400
16x18x30	44.00	36.00	21.00	21.00	42.00	86.00	94	57	174	12,700	6400
16x20x25							98	59	180	11,200	6700
18x20x30	44.00	36.00	24.00	24.00	44.00	86.00	98	62	180	12,500	6900
18x20x32							98	62	180	13,600	6900
20x20x34	46.00	38.00	26.00	26.00	45.25	88.50	102	62	180	14,200	7100
20x24x30							102	66	180	13,800	7100
24x24x25	46.00	38.00	26.00	26.00	45.25	88.50	102	66	180	12,000	7300
24x24x30							102	68	180	14,500	7300
24x24x32	52.00	48.00	27.00	27.00	48.75	98.50	102	68	180	16,200	7300
24x24x35							114	69	192	19,600	8100

PWD API 610 BB1 SINGLE STAGE PUMP

TECHNICAL DATA

PUMP SIZE	Case Min. Thick	Max. Hydro Test	STANDARD SHAFT DIMENSIONS						Ball Bearing Sizes		Sleeve Ball Thrust Brg. Size	Sleeve Pivot Shoe Pivot Shoe Size	Rated RPM	Max. BHP/ 100 RPM	Cplg. Fit Taper / Foot	Stuffing Box Dim.			Gland BC				
			Imp.	Stuff. Box	Slv. Brg.	Ball Thrust Brg.	Radial Ball Brg.	Cplg.	Thrust Brg. Size	Radial Brg. Size						Bore	Face to 1st Obstruction						
																	Int.	Ext.					
4x6x13	.50		2.13	1.88	1.88	1.77	1.77	1.88	7309	6309	7310	5-JHJ		11.5		4.75	3.38	4.38	6.31				
6x8x13			2.25	2.00	2.00		1.97	2.00		6310										4.75	3.38	4.38	6.31
8x10x13			2.50	2.25	2.25	1.97	2.16	2.25	7310	6311											22.5	5.19	3.38
8x10x15	.63		2.75	2.50	2.50			2.50					3560	26.1		5.19	3.38	4.38	6.69				
8x10x16			3.00	2.75	2.75			2.75									37.6	5.19		3.38	4.38	6.69	
10x12x15			3.25	3.00	3.00			3.00									49.2	5.50		3.38	4.38	7.13	
10x12x19	.69		3.63	3.38	3.38			3.38					1780	79.8		6.31	4.50	4.88	8.00				
10x12x25			3.63	3.38	3.38			3.38								64.6	6.31	4.50		4.88	8.00		
10x14x16			3.75	3.50	3.50			3.50								91.3	6.31	4.50		4.88	8.00		
10x14x19	.81		3.75	3.50	3.50			3.50					3560	60.1	6-JHJ	6.31	4.50	4.88	8.00				
12x12x15			3.50	3.25	3.25			3.25			7313					76.5	6.31	4.50		4.88	8.00		
12x14x16			3.50	3.25	3.25			3.25								102.8	6.75	5.50		5.13	8.75		
12x14x19	.94		4.00	3.75	3.75			3.75					1780	89.0		6.31	4.50	4.88	8.00				
14x14x15			3.75	3.50	3.50			3.50								98.3	6.75	5.50		5.13	8.75		
14x14x16			3.88	3.63	3.63			3.63								155.7	7.13	5.50		5.25	8.88		
14x14x19	.94	2220	4.50	4.25	4.25			4.25					1780	84.3		6.75	5.50	5.13	8.75				
14x14x21			4.00	3.75	3.75			3.75								98.3	6.75	5.50		5.13	8.75		
14x16x21			4.00	3.75	3.75	N/A	N/A	3.75	N/A	N/A						106.4	6.75	5.50		5.13	8.75		
14x16x25	1.00		4.00	3.75	3.75			3.75					3560	177.0		6.75	5.50	5.13	8.75				
16x16x19			4.50	4.25	4.25			4.25								134.4	7.13	5.50		5.25	8.88		
16x16x25			4.25	4.00	4.00			4.00								99.4	6.75	5.50		5.13	8.75		
16x18x21	1.00		3.88	3.63	3.63			3.63					1780	215.1		7.50	5.50	5.56	9.25				
16x18x27			4.75	4.50	4.50			4.50								123.0	7.13	5.50		5.25	8.88		
16x18x30			4.13	3.88	3.88			3.88								172.4	7.50	6.00		4.88	9.50		
16x20x25	1.13		5.25	4.75	4.75			4.75					1780	221.3		7.50	6.00	4.88	9.50				
18x20x30			5.25	4.75	4.75			4.75								268.9	7.50	6.00		4.88	9.50		
18x20x32			5.25	4.75	4.75			4.75								373.0	7.50	6.00		4.88	9.50		
20x20x34	1.25		5.75	5.50	5.50			5.50					1780	319.4	7-JHJ	7.50	6.00	4.88	9.50				
20x24x30			5.75	5.50	5.50			5.50			7317					236.5	7.50	6.00		4.88	9.50		
24x24x25			5.00	4.75	4.75			4.75								418.3	8.75	6.00		5.00	10.88		
24x24x30	1.50		6.00	5.50	5.50			5.50					1780	384.8		8.75	6.00	5.00	10.88				
24x24x32			6.00	5.50	5.50			5.50								429.1	8.75	6.00		5.00	10.88		
24x24x35			6.13	5.50	5.50			5.50										8.75		6.00	5.00	10.88	

NOTES:

1. All dimensions are in inches.
2. Hydrotest pressures based on standard 600# flange rating, at 1 1/2 maximum working pressure at 100°F for WCB material
3. Max BHP/100 RPM based on 7500# torsional shaft stress



PumpWorks 610 • www.pumpworks610.com
 8885 Monroe • Houston, TX 77061 • Ph. 888-405-0209 • Fax 713-956-2141
www.bestpumpworks.com • twitter: @PumpWorks610 • A DIVISION OF BEST PUMPWORKS